

1. First Look
2. PC Application
3. Basic Flights
4. Advanced Flights
5. Rocket Science

Appendices

- A. Specifications
- B. Mounting and Interface
- C. Standard Configurations
- D. File Formats
- E. Open Host Interface
- F. Problem Report Form
- G. Glossary

Figures

Tables

NOTE: A comment that provides additional information for the technically over-inclined, but can be safely ignored

RECCOMENDATION: A suggestion. You can ignore this, but it is a good idea.

CAUTION: Pay attention to this! Ignorance can easily lead to damage to either **CONTROL** or your rocket.

DANGER! DON'T DO THIS! Failure to heed this note can result in damage to **CONTROL**, your rocket, yourself, or others!

CONTROL refers to the flight unit itself

N-CONTROL refers to the standard PC application support program

1. First Look

Congratulations! With CONTROL you have one of the most advanced and customizable micro-avionics devices available for HPR today. Although CONTROL has many features and operational modes, it is ready-to-go out of the box and into your rocket as soon as you install a battery. This first section is designed to get you “in Control” as quickly as possible, while the following sections of this guide will allow you to learn how to fully use all of the features of this device.

1.1 The Components

The basic system components include:

- CONTROL -- the “brain” for your rocket;
- External 9V battery clip -- supplies power to CONTROL during flight;
- Serial Interface Cable -- use this to connect to a PC for downloading flight data and to configure flight parameters;
- *N-CONTROL* software CD -- PC software to download flight data and configure flight parameters;
- CONTROL Reference Guide -- you’re reading it!



Figure 1a. CONTROL System Components

Additionally, you will probably want to have:

- 9V battery -- Duracell MX1602 (6LR61) or similar;
- 3/32" flat-blade screwdriver -- McMaster-Carr 52985A13 or equivalent;
- test loads -- Radio Shack 272-1099 or similar;
- mounting hardware -- 4-40 threaded standoffs, screws, and nuts.



Figure 1b. CONTROL Support Components

1.2 The Unit

CONTROL is a multi-event controller (MEC) combining the functionality of altimeter, accelerometer, and timer units. Control has four pyrotechnic trigger channels with onboard screw terminal connectors for firing electric matches or similar devices. Each channel may be fired upon a selectable trigger event with an additional programmable time delay of up to 255 seconds. Each channel is either pulsed "on" for one half second, or may be selected to latch "on". Although the four channels are identical, three channels are named by their typical usage:

- | | |
|-------|--|
| AIR | airstart or sustainer ignition; |
| PEAK | parachute deploy upon apogee detect; |
| FLOOR | parachute deploy when altitude is below a specified "floor". |

The fourth channel, AUX, is available for additional functions such as a delayed apogee event or a landing event such as a partial release of main parachute shroud lines.

CONTROL operates by stepping through a series of states, where each state is defined by the set of trigger events that end that state and trigger the next state. Trigger events are summarized in Table I. Observe that many trigger events have an associated programmable parameter.

Trigger Event	Programmable Parameter	Typical Usage
acceleration greater than threshold	acceleration threshold	launch detect by accelerometer
acceleration less than zero	none	burnout detect
absolute velocity greater than threshold	high threshold	falling detect
absolute velocity less than threshold	low threshold	landing detect
velocity less than zero	none	apogee detect by accelerometer
altitude greater than ceiling	ceiling altitude	launch detect by altimeter
altitude less than peak	delta altitude	apogee detect by altimeter
altitude less than floor	floor altitude	mains deploy for dual deployment
AUX channel open	none	breakwire detect
AUX channel closed	none	external switch closure detect
timeout	state timeout	time delay

Table I. CONTROL Trigger Events

CONTROL performs a series of self-test at startup. After passing these tests, CONTROL enters the "launch detect" state. Upon detection of a launch event such as "acceleration above threshold", CONTROL begins to step through its states program. CONTROL also operates as a data logger during flight, recording both altitude and acceleration data sixteen times per second. CONTROL finishes in the "idle" state at the completion of the flight.

The power of CONTROL lies in that the states, trigger events, and trigger parameters are fully user programmable. A PC application, *N-CONTROL*, supports programming of custom flight programs, as well as enabling a selection of standard programs such as "deploy at apogee" or "dual deploy with airstart". *N-CONTROL* is also able to download, display, and save logging data acquired during the flight.

1.3 First Flight

As shipped, CONTROL is configured to:

- require a battery voltage greater than 6.5 Volts;
- require a connection on the "PEAK" pyro channel;
- detect launch by acceleration greater than 2.1G;
- fire the "AIRSTART" channel at first burnout detect;
- fire the "PEAK" channel at apogee;
- fire the "FLOOR" channel at 660 feet (200 meters) AGL;
- fire the "AUXILIARY" channel 3 seconds after landing.

This initial configuration allows flight configurations such as

- single deploy at apogee;
- dual deploy;
- single or dual deploy with airstart or sustainer firing;
- partial shroud release at landing (using a device such as Tether).

You can also fly CONTROL as "payload only" to log flight events. To do this with the initial configuration you must connect a dummy load to the "PEAK" pyro channel, such as a small lamp or a 10 K, 1/4 W resistor. If you would rather first ground-test CONTROL under simulated conditions instead of using the unit in an actual flight, jump ahead to Section 3.3, then come back to Section 1.3 to see how to download the data.

Installation

CONTROL will mount into an inside tube diameter of 1.5" or larger. Refer to Appendix B for detailed mounting dimensions.

CAUTION: Use the proper size mounting hardware (#4). Do not drill out the mounting holes!

You can use the on-board rotary power switch and LED for minimum ID applications. If you are installing CONTROL in a larger tube, we suggest that you use an external switch and LED indicator (or piezo beeper), as are further described in Section 3.2.

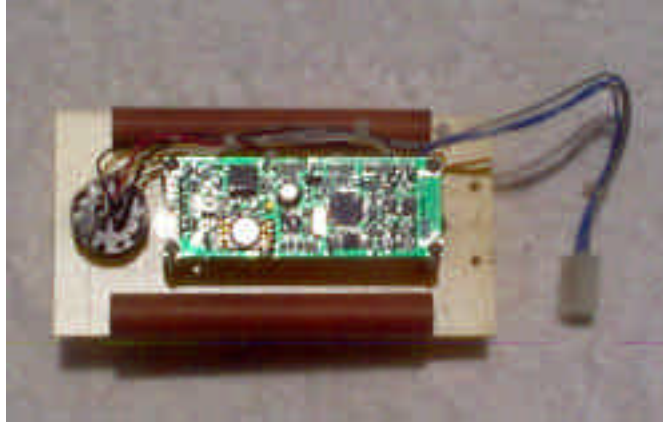

Figure 1e. Example CONTROL Installation

CAUTION: Observe the “This End Up” label on the CONTROL PC board. This orientation is necessary for the accelerometer sensor to properly register “positive” versus “negative” accelerations.

Flight Prep

Plan your flight, then:

- 1) Connect the charges.

Connect pyrotechnic charges to CONTROL to match your flight plan per the usage described in Table II below.

Mission	Connect to PEAK	Connect to FLOOR	Connect to AIR	Connect to AUX
deploy at peak	main chute	<i>open</i>	<i>open</i>	<i>open</i>
airstart with peak deploy	main chute	<i>open</i>	sustainer ignitor(s)	<i>open</i>
dual deploy	drogue	main chute	<i>open</i>	<i>open</i>
airstart with dual deploy	drogue	main chute	sustainer ignitor(s)	<i>open</i>
airstart with dual deploy & landing event	drogue	main chute	sustainer ignitor(s)	TETHER, smoke charge, ...

Table II. Standard CONTROL Channel Functions

You may also use the default CONTROL configuration for data logging only. In that case, you must still connect something to the PEAK pyro channel when using the initial configuration, otherwise the unit will not arm. A test bulb is ideal for this purpose. **DO NOT** use a simple wire jumper across the PEAK channel terminals, as this will directly short the battery when the PEAK channel is triggered by the default configuration. A 10 K, 1/4 W resistor is also satisfactory for this purpose. Alternately, you can disable the PEAK channel continuity check. See Section 4.1 for information on how to accomplish this.

2) Install the battery.

For a basic installation attach a 9V battery using the supplied connector and clip. Plug the clip onto the connector at the aft end of the board, then connect a 9V battery to the clip.

CAUTION: Do not connect a battery with reversed polarity, even momentarily. Doing so will damage the unit. Secure the battery so that it will not move or become disconnected during flight.

It is also possible to use an alternate battery, such as a 9.6V R/C battery pack, by wiring it either to the board connector or by directly soldering connections to the appropriate pads adjacent to the connector. Refer to Section 4.2 for more information on how to do this.

3) Test for continuity to the charges.

If possible, test the charges without black power (or whatever you are using). To test the charges, turn power on to the device. The unit should begin a series of brief flashes at a rate of one per second for about ten seconds during its start-up self tests, and then it will begin blinking rapidly to indicate that it is armed and ready to detect launch. If the unit does not begin to flash rapidly after about 15 seconds, the most likely cause is lack of continuity across the PEAK pyro channel. Alternate causes are insufficient battery voltage (less than 6.5 Volts in the initial configuration) or a defective altimeter or acceleration sensor.

CAUTION: The initial CONTROL configuration does not require continuity on the FLOOR, AUX, and AIR channels. Refer to Section 4.1 to see how to require continuity checks for these channels.

Once continuity has been confirmed by the unit blinking rapidly, turn the power off and add black powder (or alternate), if necessary.

4) Install the unit.

Install CONTROL into the rocket. If the unit is being flown as "payload only", it is OK to leave the unit powered on now, otherwise do not re-arm the unit until the rocket is mounted on the pad.

At the Pad

CONTROL may be armed in any position as long as the launch detect acceleration is set greater than 2.1 G (the default). When ready to arm the unit, power it on and wait for the rapid blinking that indicates that the unit is armed and awaiting launch.

Recovery

When CONTROL has completed data acquisition for a flight, the status LED will give one short blink every second. Power the unit off. If you were using the unit for logging only with the initial program configuration, remove the dummy load from the PEAK channel.

CONTROL logs data from about ten seconds before launch and for up to 500 seconds after launch.

Disconnect the battery when you remove the unit from your rocket. Do not store CONTROL with a battery installed.

1.4 Data Download

Software Installation

Before you can download data you must first install the application software from the *N-CONTROL* software CD. The *N-CONTROL* application is compatible with Microsoft Windows® operating systems that use the Win32 API. To install the software, simply drag the *N-CONTROL* folder from the CD onto your hard disk drive. An alias to the application is located in the *N-CONTROL* folder. Drag that alias onto your desktop for rapid startup of the program.

Connect to CONTROL

Connect the DB9 end of the PC serial interface cable to your computer. By default, *N-CONTROL* will use the COM1 port. Connect the other end of the cable to the connector at the aft end of CONTROL. If you have used CONTROL in a logging-only flight using the initial configuration, make sure that you have removed the dummy load from the PEAK channel, otherwise the unit will re-arm itself for flight and begin to overwrite previously acquired flight data.

Note that CONTROL uses power from the serial port (pin 4) to power the unit during data download and flight configuration. If your computer does not supply sufficient power over pin 4, an external battery connection will be required. Refer to Section 3.2 for details on implementing an external battery connection during data communications.

Run the Application

Double-click on the application icon or its alias to start program execution.

Download the Data

Select "Get Flight" from the "Control" menu to download flight data. If you receive an error message, recheck the connections and recheck that you are connected to the correct port and try again. If you still receive an error message, the most likely reason is that your COM1 port is not supplying power to CONTROL. In that case you should try using an external power connection as described in Section 3.2. In rare cases the problem may be that your computer does not support the required 57.6 Kbaud data rate. If you know this is the case, contact *DefyGravity* for alternate firmware and software to support your computer.

A typical data download takes less than fifteen seconds. The result should be a graph of flight acceleration and altitude and a set of tab control panels with information on the flight located at the left side of the window. An example flight graph window is given in Figure 1d.

The flight graph displays flight acceleration and altitude relative to launch conditions. Data is displayed from a few seconds before launch detect to a few seconds after landing (up to the 500 second limit).

Use the tab select panels to view information about the flight. Use the "Plot" panel to modify the display graph. Refer to Section 2 to learn more about how to use the *N-CONTROL* PC application.

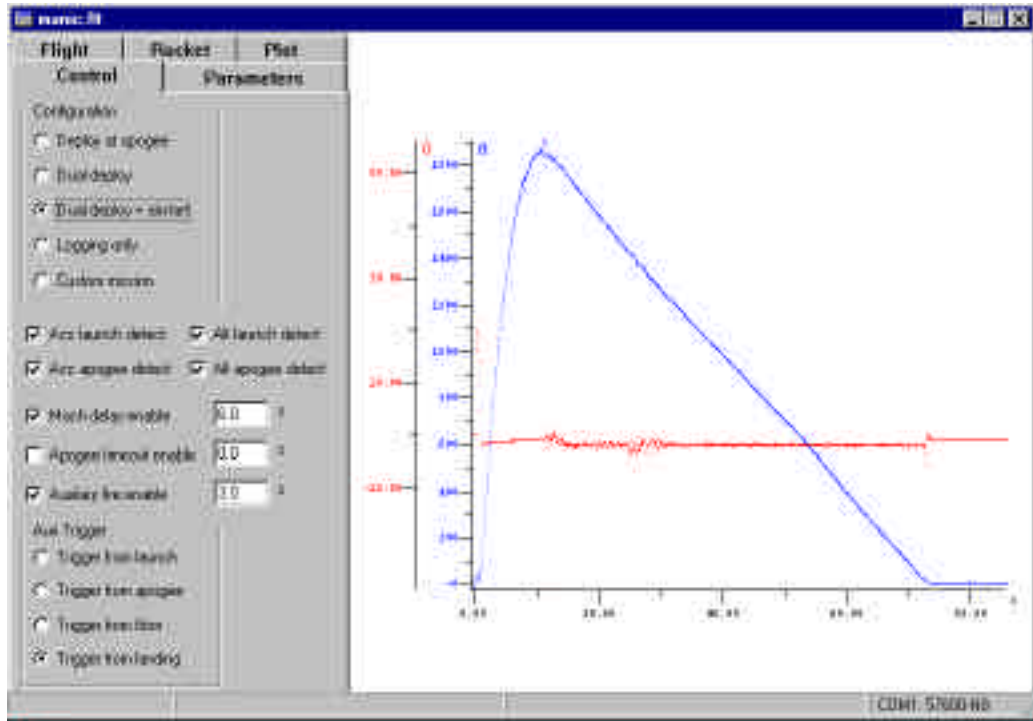

Figure 1d. CONTROL Flight Graph

1.5 Web Updates

Check the DefyGravity web site www.defygravity.com for the most recent version of the CONTROL user guide and the *N-CONTROL* application. CONTROL firmware updates are also available from the website. CONTROL firmware is downloaded into the unit over the serial communications link using the *N-CONTROL* application. Refer to Section 4.2 for detailed information on this procedure.

The Menu Bar

Menu bar commands are summarized in Section 2.4. The "File" menu contains commands to open and save control parameter and flight data files. The "Edit" menu contains the standard cut/copy/paste commands and a command to set the default user preferences. The "Control" menu contains most of the application specific commands. The "Window" menu is a standard MDI command menu, and the "Help" menu links to application documentation as well as enabling low-level hardware diagnostic functions.

Many menu commands are modal, and are typically disabled until the appropriate tab panel is selected. Low-level diagnostic commands are password protected.

The Control Tab Panels

The "Control" and "Parameters" tab panels are always present in a control window.

Control	basic states configuration, such as "Deploy at apogee", "Dual deploy", or "Logging Only" selections. Section 2.2
Parameters	flight parameters configuration, such as "Acceleration threshold" and "Pressure floor". Section 2.2

When flight data is also available, the "Flight", "Rocket", and "Plot" tab panels are also displayed.

Flight	flight information summary, such as "Peak altitude" and "Peak fire" time. Section 2.1
Rocket	ancillary data such as "Rocket Name" and derived data such as "Velocity @ floor fire" Section 2.1
Plot	graph configuration, including such display parameters as "Acceleration" range and options such as "Plot vel. from alt." Section 2.1

The Graph Pane

The graph pane is displayed only when flight data is available, either from a data download from CONTROL, or from a previously saved ".flt" file. The display parameters are configured by the "Plot" tab control panel.

2.1 Data Download and Analysis

Download Flight Data from CONTROL

Make sure that CONTROL is connected to your PC as previously described at the beginning of Section 2. Then select “Control ... Get Flight” to download data from the unit’s EEPROM log. Operation status and progress is displayed in the lower-left side of the status bar at the bottom of the main *N-CONTROL* application window. A download operation typically requires about 15 seconds to complete.

Once the data download is complete, an *N-CONTROL* flight data window will be displayed, similar to the one depicted in Figure 1d.

Flight Data Tab Control Panels

The “Flight”, “Rocket”, and “Plot” tab control panels are used to display logged and derived flight data and to configure the graphics plot on the right hand side of the flight data window. Display unit preferences are set by “Edit ... Preferences ...”.



Control	Parameters
Flight	Rocket Plot
Launch impedance	183 Ω
Launch height	3025 ft
Peak altitude	4800 ft
Flight number	2
Aerball time (s)	0.75 s
Peak time (s)	7.44 s
Flare time (s)	40.12 s
Ascent time (s)	30.70 s
Entry of launch	00 Volts
Entry of contact	00 Volts
Entry of peak time	00 Volts
Entry of flare time	00 Volts
Entry of low time	00 Volts

Figure 2.1a “Flight” Tab Control Panel

Launch temperature	On-board temperature a moment of launch detect. May be edited to set the actual launch site temperature.
Launch altitude	Measured pressure altitude at moment of launch detect. As the pressure altitude is weather dependent, this parameter may be set the actual launch site altitude.
Peak altitude	Maximum altitude as measured by the pressure sensor.
Flight number	Sequential flight number of the flown CONTROL unit.
Airstart fire @	Time of airstart channel firing, or zero if not fired.
Peak fire @	Time of peak channel firing, or zero if not fired. The peak channel is typically used for drogue deploy at apogee or for single (main) deploy at apogee.
Floor fire @	Time of floor channel firing, or zero if not fired. The floor channel is typically used for main firing at or below a specific altitude (the pressure <u>floor</u>).
Auxiliary fire @	Time of auxiliary channel firing, or zero if not fired (fired upon landing detect in default CONTROL configurations).
Battery at launch	Battery voltage at moment of launch detect.
Battery at airstart	Battery voltage at moment of firing the airstart channel.
Battery at peak fire	Battery voltage at moment of firing the peak channel.
Battery at floor fire	Battery voltage at moment of firing the floor channel.
Battery at aux. fire	Battery voltage at moment of firing the auxiliary channel.

The “Flight” tab control panel displays information captured during a flight that is in addition to the normally logged acceleration and altitude samples.

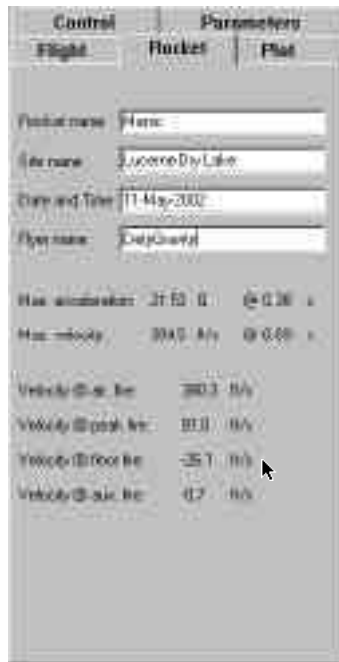

Figure 2.1b "Rocket" Tab Control Panel

Rocket name	field is user defined text.
Site name	field is user defined text.
Date and Time	field is user defined text.
Flyer name	field is user defined text.
Max. acceleration	value and time from launch of the maximum acceleration occurring before apogee detect.
Max. velocity	value and time from launch of maximum velocity occurring before apogee detect.
Velocity @ air fire	velocity (from acceleration sensor) at time of airstart event.
Velocity @ peak fire	velocity (from altitude sensor) at time of peak event.
Velocity @ floor fire	velocity (from altitude sensor) at time of floor event.
Velocity @ aux. fire	velocity (from altitude sensor) at time of auxiliary event.

The "Rocket" tab control panel contains post-flight data input and analysis results.



Figure 2.1c "Plot" Tab Control Panel

Acceleration	lower and upper bounds for the displayed acceleration axis.
Plot acceleration	check to plot acceleration (from accelerometer); set low-pass corner frequency for smoothing the acceleration plot.
Plot vel. from acc.	check to plot velocity (from accelerometer); set low-pass corner frequency for smoothing the velocity plot.
Plot alt. from acc.	check to plot altitude (from accelerometer); set low-pass corner frequency for smoothing the altitude plot.
Velocity	lower and upper bounds for the displayed velocity axis.
Plot acc. from alt.	check to plot acceleration (from altimeter); set low-pass corner frequency for the acceleration plot.
Plot vel. from alt.	check to plot velocity (from altimeter); set low-pass corner frequency for the velocity plot.
Plot altitude	check to plot altitude (from altimeter pressure sensor); set low-pass corner frequency for the altitude plot.
Time	lower and upper bounds for the displayed time axis (independent variable).
Rescale	Set dependent axis bounds for displayed time range.
Revert	Reset all dependent axis bounds to initial limits.
Apply	Apply current selections to redraw the graph pane.

Saving and Exporting Flight Data

Use the "File ... Save" or "File ... Save As" menu commands to save a flight window. Two file formats are supported:

- "`.flt`" save all parameters and flight data;
- "`.txt`" save flight data log only.

Both file formats are saved in a human-readable ASCII format. Use the "`.txt`" format to save flight data in a simple format without ancillary parameters. All file values are saved in metric meter-kilogram-seconds (MKS) units.

Loading an Old Flight

Use the "File ... Open" command to restore a flight file from a "`.flt`" file. Loading flight data from a "`.txt`" file is not supported.

2.2 Flight Configuration

Configuring a New Flight

Use the "Control" tab panel to select a basic flight configuration, and then the "Parameters" tab panel to edit flight parameters. Configuration for a basic flight is further discussed in Section 3.1, while configuration for advanced flights is discussed in Section 4.1.

Note the initial "out-of-box" flight configuration as discussed in Section 1 is not directly selectable as one of the basic flight configurations on this panel. This initial flight configuration may be restored from the file "`standard.msc`" using the menu command "File ... Open", but it is not recommended once the use of the basic flight configurations is understood.



Figure 2.2a "Control" Tab Control Panel

Deploy at apogee	select for single deployment at apogee detect; continuity will be required on the peak trigger channel.
Dual deploy	select for dual deployment upon apogee detect and descent below floor altitude; peak and floor trigger channel continuity will be required.
Dual deploy + airstart	select for airstart upon first burnout detect followed by dual deployment at apogee detect and descent below floor altitude; airstart, peak and floor trigger channel continuity will be required.
Logging only	select for data logging only of acceleration and altitude; no trigger channel continuities will be required.
Custom mission	indicated that a non-standard flight mission configuration has been created through use of advanced editing features.

Whenever the "Control" tab control panel is selected, the present configuration is scanned. This radio position is selected automatically if the configuration does not match one of the basic configurations.

Acc launch detect	select to enable launch detect using accelerometer data.
Alt launch detect	select to enable launch detect using altimeter data.

CAUTION: At least one of "Acc launch detect" or "Alt launch detect" should be checked for a basic flight configuration or launch cannot be detected.

Acc apogee detect	select to enable apogee detect using accelerometer data (negative velocity by integrated acceleration).
Alt apogee detect	select to enable apogee detect using altitude data (negative velocity by delta altitude).
Mach delay enable	select to enable a delay time between burnout detect and checking for apogee; set the delay time in seconds from burnout detect.
Apogee timeout enable	select to enable a timeout for detection of apogee; set the timeout from the end of mach delay in seconds.
Auxiliary fire enable	select to enable firing of the auxiliary trigger channel at a fixed delay time from detection of the selected trigger event.
Trigger from launch	select to trigger the auxiliary channel from launch detect.
Trigger from apogee	select to trigger the auxiliary channel from apogee detect.
Trigger from floor	select to trigger the auxiliary channel from descent below floor detect.
Trigger from landing	select to trigger the auxiliary channel from landing detect.

The "Control" tab control panel is primarily used to select a basic flight configuration. It may also be used to quickly set up a starting configuration for an advance flight plan.



Figure 2.2b "Parameters" Tab Control Panel

Acceleration threshold lower limit for an acceleration event detect; exceeding this threshold can create an "acceleration" event.

The acceleration threshold parameter is typically used to set the launch detect acceleration threshold (when the "Control" item "Acc launch detect" is selected).

Pressure ceiling sets the ceiling altitude; exceeding this altitude can create a "ceiling" event.

The pressure ceiling parameter is typically used to set the altitude exceeded launch detect threshold when the "Control" item "Alt launch detect" is checked. It may also be used to disable detection of other events until the rocket has exceeded the ceiling altitude in advanced flight configurations.

Pressure floor sets the floor altitude; being below this altitude can create a "floor" event.

The pressure floor parameter is typically used to set the main parachute deploy altitude in dual deploy configurations.

Landing threshold sets the landing detect velocity limit; descending (or ascending) at a velocity less than this value can create a "landing" event.

The landing threshold is typically used to trigger an auxiliary trigger channel firing.

FALLING! threshold sets a maximum descent velocity limit; descending at a velocity greater than this value can create a “falling” event.

A falling event can be used in an advanced flight configuration to trigger an event action, such as immediately deploying the main parachute in the event of a drogue deployment failure.

Minimum battery voltage sets the minimum battery voltage for unit arming when CONTROL performs its self-tests.

The minimum battery voltage parameter is only used if the “Check battery” option is checked in the “Checks...” dialog (see Section 4.1, “Pre-Flight Self-Tests”, for more information).

AIRSTART delay sets a delay in seconds from an airstart trigger event until the AIR pyro channel actually fires.

PEAK delay sets a delay in seconds from a peak trigger event until the PEAK pyro channel actually fires.

FLOOR delay sets a delay in seconds from a floor trigger event until the FLOOR pyro channel actually fires.

AUXILIARY delay sets a delay in seconds from an auxiliary trigger event until the AUX pyro channel actually fires.

Saving and Exporting a Flight Configuration

Use the “File ... Save” or “File ... Save As” menu commands to save a flight configuration. A flight configuration is saved as a “.MSC” file in a human-readable ASCII format. All file values are saved in MKS units.

Loading an Old Flight Configuration

Use the “File ... Open” command to restore flight parameters from a “.MSC” file.

2.3 Advanced Data Plotting

Acceleration and altimeter (barometric pressure) samples acquired by CONTROL during a flight are plotted in the graphics pane area that forms the right-hand side of a flight window. Using the "Plot" tab control panel, up to six different plots may be displayed:

Acceleration from accelerometer flight accelerations from accelerometer samples.

Acceleration data samples (corrected for the acceleration component induced by Earth's gravity) are directly plotted.

Velocity from accelerometer velocity derived from accelerometer samples.

Velocity is derived by integrating the acceleration data samples. This velocity is most accurate during the boost phase, and is generally inaccurate after apogee.

Altitude from accelerometer altitude derived from accelerometer samples

Altitude is derived by doubly integrating the acceleration data samples. This altitude is most accurate during the boost phase, and should be considered inaccurate after apogee.

Acceleration from altimeter acceleration derived from the altimeter samples.

Acceleration is derived by taking the second derivative of altimeter data samples. This plot is much "noisier" than the direct acceleration data plot, but it is valid regardless of the flight phase. Use low pass filtering to reduce displayed noise.

Velocity from altimeter velocity derived from the altimeter samples.

Velocity is derived by taking the first derivative of altimeter data samples. This plot is "noisier" than the velocity derived by integrating the accelerometer data samples, but it is valid regardless of the flight phase. This data is most useful for determining descent velocities when under parachute. Use low pass filtering to reduce displayed noise

Altitude from altimeter flight altitude from altimeter samples.

Altimeter data samples (as determined by barometric pressure) are directly plotted as altitude above ground level (AGL).

Filtering

Each of the plots may be individually filtered to minimize the displayed acquisition noise. The -3db Hz set points in the "Plot" tab control panel set the low pass frequency for the associated plot. For a smoother curve, set a lower number (lower frequency response). The selected frequency should be selected from a domain of 0.2 to 8 Hz.

NOTE: Remember that 1 Hz (Hertz) represents one cycle per second. The -3db point of the filter represents the frequency of a sine wave that would be reduced to 0.707 of its initial amplitude when passed through the filter.

NOTE: The sample acquisition rate of CONTROL during flight is 16 Hz, which results in an upper (Nyquist) frequency limit response of 8 Hz. Thus, setting the filter set point to a higher frequency is meaningless, as are frequency values less than zero. Also, the application *N-CONTROL* presently implements the low pass filter as a 127 tap FIR (finite impulse response) filter, which means that low pass cutoffs below about 0.25 Hz have little additional affect.

The standard filter is a simple cosine window. The cosine window gives intuitive results, but can result in large amplitude errors when used to implement a heavy low-pass response. A sinc ($\sin x / x$) or moving average response may also be selected using the "Edit Preferences ... Display" tab dialog, as described in Section 2.4. The sinc response give the most accurate amplitude response, but will display an annoying "ringing" behavior around sharp transient events such as launch and deployments. The moving average response is supported only because it is commonly used. It results in a poor response by allowing an excessive amount of noise above the selected low-pass -3db frequency to pass through the filter.

Notes Regarding Velocity and Altitude Derived from the Accelerometer

Velocity and altitude are derived from accelerometer samples by integrating (summing) that data. Velocity is integrated acceleration, and altitude is integrated velocity (doubly integrated acceleration).

The acceleration sensor senses a +1 G acceleration due to Earth's gravity when oriented vertically for launch. This component is measured before flight and is subtracted to allow integration for rocket velocity and altitude. However, as the rocket tilts from vertical during flight, the correction value becomes invalid (too large) and the calculated velocity and altitude will become increasingly inaccurate and generally useless after the rocket reaches apogee. For more information of this

effect, and other sources of error in accelerometer measurements, refer to Section 5.1, "Understanding the Accelerometer".

The act of integration generates a smoother data plot. Additional low-pass filtering is generally not useful on velocity and altitude plots derived from accelerometer data.

Notes Regarding Velocity and Acceleration Derived from the Altimeter

Velocity and acceleration are derived from altimeter samples by differentiating (taking the difference between adjacent samples) that data. Velocity is the derivative of altitude, and acceleration is the derivative of velocity (second derivative of altitude).

The act of differentiation generates a "noisier" data plot as it emphasizes short duration (high frequency) events. Heavy low-pass filtering is usually required to display a meaningful plot. These plots are valid regardless of the tilt angle of the rocket, however, and the velocity derived from altimeter data is very useful to display descent rates.

As the altitude is determined by CONTROL using a barometric pressure sensor comprising micro-mechanical components, the altitude reading (and derived velocity and acceleration) can be temporarily upset by high acceleration events, such as parachute deployment or high-G launches. Also, pressure "blow-by" of a pyrotechnic charge can result in an apparent altitude spike, and even damage the sensor in extreme instances. For a discussion of these and other effects on altitude measurements from barometric pressure, refer to Section 5.2, "Understanding the Altimeter".

2.4 User Preferences

User preferences are saved and restored from the initialization file "NControl.ini". It is possible to edit this file directly with a text editor, but usually it is more convenient to set personal preferences using the "Edit Preferences..." dialog. This dialog comprises three tab panels:

Units	sets preferred display units;
Display	sets default graphing preferences;
Paths	sets default save/restore file paths.

A standard set of buttons is common to all of these tab panels:

Accept	accept the selections for the duration of the current application session and quit the dialog;
Cancel	reject any edited selection and quit the dialog;
Save	accept the selections as the new defaults and save in the "NControl.ini" startup file;
Reset	immediately restore the preferences from the "NControl.ini" startup file.

Units Preferences

The internal units use by *N-CONTROL* are meters-kilograms-seconds (MKS). The “Units” dialog panel sets display preferences for altitude, velocity, and acceleration.

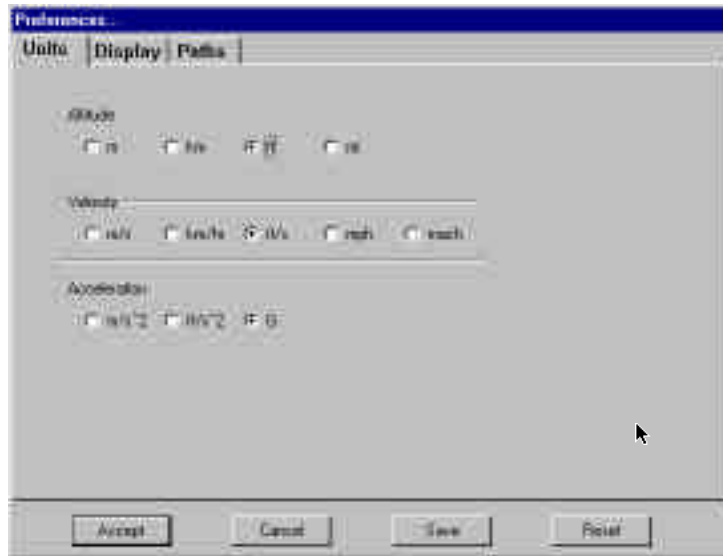

Figure 2.4a Unit Preferences Panel

m	display altitudes in meters
km	display altitudes in kilometers
ft	display altitudes in feet
mi	display altitudes in miles
m/s	display velocities in meters per second
km/hr	display velocities as kilometers per hour
mph	display velocities as miles per hour
mach	display velocities at fraction of sound velocity at sea level
m/s ²	display acceleration as meters per second per second
ft/s ²	display acceleration as feet per second per second
G	display acceleration as fraction of standard gravity

Display Preferences

The “Display” dialog panel sets default flight graph options. Selected graphs will be displayed by default when opening a new flight data window.

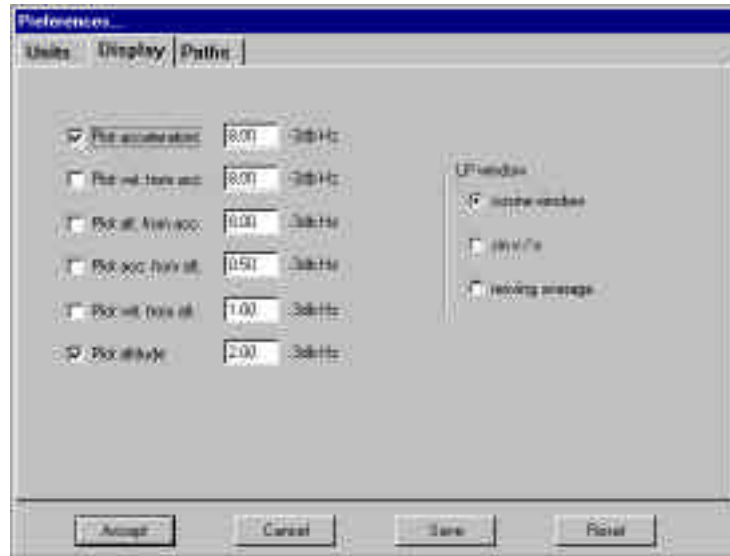

Figure 2.4b “Display” Preferences Panel

Plot acceleration	Plot acceleration graph from accelerometer data; set display low pass filtering;
Plot vel. from acc.	Plot velocity graph from accelerometer data; set display low pass filtering;
Plot alt. from acc.	Plot altitude graph from accelerometer data; set display low pass filtering;
Plot acc. from alt.	Plot acceleration graph from altimeter data; set display low pass filtering;
Plot vel. from alt.	Plot velocity graph from altimeter data; set display low pass filtering;
Plot altitude	Plot altitude graph from altimeter data; set display low pass filtering.
cosine window	Use a cosine window for low pass filtering.
sin x / x	Use a sin x / x impulse response for low pass filtering.
moving average	Use a moving average window for low pass filtering.

Paths Preferences

The “**Paths**” preferences dialog panel sets default directories for *N-CONTROL* files and to download new firmware to *CONTROL*.

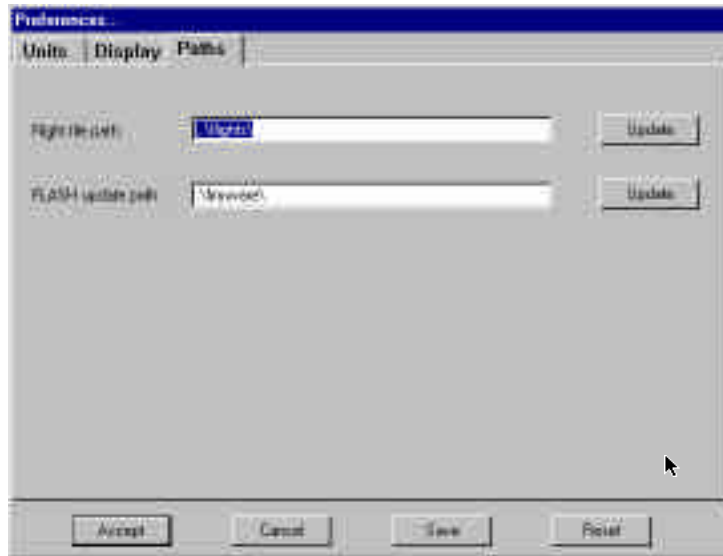

Figure 2.4c “Paths” Preferences Panel

- | | |
|-------------------|---|
| Flight file path | Set the default path to save/restore “.flt” and “.msc” flight data files; press “Update” to modify; |
| FLASH update path | Set and select a firmware update file; press “Update” to initiate the firmware update process. |

Section 4.4

The FLASH update path is used to access and download firmware updates for *CONTROL*. This procedure is described in Section 4.4.

2.5 Menu Reference

"File" Menu

Open	open a ".flt" flight data or ".msc" control parameters file Section 2.1, Loading an Old Flight Section 2.2, Loading an Old Flight Configuration
Save	save a flight data file or control parameters with the present window name Section 2.1, Saving and Exporting Flight Data Section 2.2, Saving and Exporting a Flight Configuration
Save As	save a flight data file or control parameters with a user specified file name Section 2.1, Saving and Exporting Flight Data Section 2.2, Saving and Exporting a Flight Configuration
Page Setup...	configure printer options
Print	print the selected window
Exit	exit the application

"Edit" Menu

Undo	undo the last operation not implemented
Cut	copy selection to clipboard and delete not implemented
Copy	copy selection to clipboard as a bitmap
Paste	insert selection at insertion point not implemented
Delete	delete selection not implemented
Preferences...	edit user preferences Section 2.4

“Control” Menu

The “Control” menu contains commands pertaining to flight programming.

Calibrate	calibrate unit MKS conversions Section 4.3
New Control	create a new control parameters pane with default settings Section 3.1
Set Control	save control parameters to CONTROL via the serial port Section 3.1
Get Control	get control parameters from CONTROL via the serial port Section 3.1
Get Flight	get last flight log and control parameters from CONTROL via the serial port Section 2.1
States	view/edit the control states settings details
Channels	view/edit the control channels settings details
Checks	view/edit the self-test settings details
Run Simulation	generate a flight simulation not currently implemented

“Window” Menu

The “Window” menu is the standard MDI command menu.

Cascade	align all open windows
Arrange Icons	align minimized windows

Each open window has an entry in the “Window” menu. Selecting the entry brings the window to the foreground.

“Help” Menu

Contents	display “Help” table of contents <i>not implemented</i>
Search	search “Help” contents <i>not implemented</i>
About Control...	view program version and publication information
Get EEPROM image	get total copy of EEPROM contents for diagnostics

The “Get EEPROM image” command makes a total copy of EEPROM contents, including flight parameters, settings, and logging data. Use this command in the event of a suspected CONTROL malfunction to capture the unit state and report the problem to *DefyGravity*.

RECCOMENDATION: If you ever have a problem with either a CONTROL flight or displaying post-flight data with *N-CONTROL*, use this command to save the complete post-flight state of your unit. This capture can aid *DefyGravity* in determining the cause (and resolution) to the problem.

Enable Diagnostics	enable CONTROL diagnostics <i>manufacturer command, password protected</i>
--------------------	--

Diagnostic functions are reserved for manufacturer testing.

Restore EEPROM image	put total copy of EEPROM contents for diagnostics <i>manufacturer command, password protected</i>
Get FLASH Image	get total copy of FLASH memory for diagnostics <i>manufacturer command, password protected</i>
Configuration...	diagnostics edit of low-level CONTROL setup <i>manufacturer command, password protected</i>

3. Basic Flights

The philosophy of CONTROL is that you plan your flight. CONTROL then flies your plan. Many flight plans are very similar, however, and the PC application *N-CONTROL* supports this by saving and editing flight programs. Once you are familiar with configuring CONTROL for basic flights you can comfortably move on to customizing the basic configurations for advance flights and your most complicated projects.

3.1 Basic Flight Programming

To configure CONTROL with a basic flight program, open a new *N-CONTROL* window by selecting the "Control ... New Control" menu item. A basic flight program is selected with a "Configuration" radio control in the "Control" tab panel (Figure 2.2a). Once the basic flight program is selected, other "Control" tab panel options modify that configuration. Additional flight program parameters may be edited using the "Parameters" tab dialog. Table III summarizes the basic flight configurations.

state	Deploy at Apogee	Dual Deploy	Dual Deploy + Airstart	Logging Only
0: Launch Detect	ACC < threshold ALT > ceiling <i>no timeout</i>	ACC < threshold ALT > ceiling <i>no timeout</i>	ACC < threshold ALT > ceiling <i>no timeout</i>	ACC < threshold ALT > ceiling <i>no timeout</i>
1: Burnout Detect	ACC < zero <i>12 s timeout</i>	ACC < zero <i>12 s timeout</i>	ACC < zero <i>12 s timeout</i> Fire AIR!	ACC < zero <i>12 s timeout</i>
2: Mach Delay	VEL < zero <i>6 s timeout</i>	VEL < zero <i>6 s timeout</i>	VEL < zero <i>6 s timeout</i>	VEL < zero <i>6 s timeout</i>
3: Apogee Detect	VEL < zero ALT < apogee <i>no timeout</i> Fire PEAK!	VEL < zero ALT < apogee <i>no timeout</i> Fire PEAK!	VEL < zero ALT < apogee <i>no timeout</i> Fire PEAK!	VEL < zero ALT < apogee <i>no timeout</i>
4: Floor Detect	ALT < floor <i>no timeout</i>	ALT < floor <i>no timeout</i> Fire FLOOR!	ALT < floor <i>no timeout</i> Fire FLOOR!	ALT < floor <i>no timeout</i>
5: Landing Detect	VEL < low limit <i>no timeout</i>	VEL < low limit <i>no timeout</i>	VEL < low limit <i>no timeout</i>	VEL < low limit <i>no timeout</i>
6: Idle Delay	<i>5s timeout</i>	<i>5s timeout</i>	<i>5s timeout</i>	<i>5s timeout</i>
<i>checks required</i>	PEAK	PEAK, FLOOR	PEAK, FLOOR, AIR	<i>none</i>

Table III. Basic Flight Configurations

Once a flight program is configured, it is downloaded to CONTROL by selecting the "Control ... Set Control" menu command. The flight program may be saved as a ".msc" file by selecting the "File ... Save" or "File ... Save As" command and then later restored and edited.

Setting the Flight Configuration

- 1) Create a new flight configuration window using "Control ... New Control". Make sure that the "Control" tab panel is selected.
- 2) Select the desired basic flight configuration with a radio control in the "Configuration" group. Ignore the option "Custom mission", which indicates that an advanced flight program has been configured.
- 3) Use the check boxes below the "Configuration" group to customize the selected flight configuration. Refer back to Section 2.2 for more information on the individual dialog controls.
- 4) Select a functionality for the AUX pyro trigger channel with a radio control in the "Aux Trigger" group. This selection is irrelevant if you are not using the AUX channel.

Instead of creating a new flight configuration, you may open an existing ".msc" configuration file with the "File ... Open" menu command and then edit it.

Setting the Flight Parameters

Use the "Parameters" tab panel to review and edit the flight configuration parameters such as "Acceleration threshold" for launch detect or "Pressure floor" for mains deploy in a dual deploy configuration.

- 1) Select the "Parameters" tab panel.
- 2) Review the "Acceleration threshold" setting if "Acc launch detect" is enabled, otherwise this parameter is ignored.
- 3) Review the "Pressure ceiling" setting if "Alt launch detect" is enabled, otherwise this parameter is ignored.
- 4) Review the "Pressure apogee" setting if "Alt apogee detect" is enabled, otherwise this parameter is ignored.

CAUTION: Acceleration threshold -- it is NOT RECOMMENDED to ever set the acceleration threshold to a value less than 1.5 G. AT SETTINGS LESS THAN 2.1 G IT IS POSSIBLE TO EASILY TRIGGER AN ACCELEROMETER LAUNCH DETECT EVENT BY RAPIDLY ROTATING THE UNIT! It is difficult (but possible) to falsely trigger CONTROL with an acceleration threshold greater than 2 G.

CAUTION: Pressure ceiling -- it is NOT RECOMMENDED to set the pressure ceiling below 200 ft (60 m) to minimize the possibility of a false altitude launch detect event. Ceilings of 300 ft (90 m) or above are typical.

CAUTION: Pressure apogee -- it is NOT RECOMMENDED to set a pressure apogee detect value less than 20 ft (7 m) to minimize the possibility of a false altitude apogee detect event. This parameter has no impact on a velocity apogee detect, which uses accelerometer data to derive the ascent velocity.

CAUTION: Landing threshold -- it is NOT RECOMMENDED to set a landing threshold velocity less than 3 ft/s (0.9 m/s) to minimize the possibility of a false landing detect event.

If you desire to delay the firing of a pyro channel from its trigger event, set a non-zero delay time in the appropriate "AIRSTART delay", "PEAK delay", "FLOOR delay", or "AUXILIARY delay" edit fields. Refer back to Section 2.2 for a discussion of other "Parameters" tab panel dialog items.

Putting the Flight Program to CONTROL

Once the flight configuration has been selected and a review of the flight parameters has been performed, you must download the flight program to CONTROL.

- 1) Connect CONTROL to your PC. It should not be necessary to separately power the unit 'on' if your serial port powers the "Carrier Detect" line.
- 2) Downloaded the flight program to CONTROL by selecting the "Control ... Set Control" menu command.

To save the flight program for reference or editing, save the configuration as a ".msc" file by selecting the "File ... Save" or "File ... Save As" command.

Getting the Flight Configuration

You can retrieve a flight program from CONTROL to view or further edit the flight configuration.

- 1) Connect CONTROL to your PC. It should not be necessary to separately power the unit 'on' if your serial port powers the "Carrier Detect" line.
- 2) Up the flight program to the PC by selecting the "Control ... Get Control" menu command. A new window will appear with the uploaded flight configuration.

Use the "File ... Save" or "File ... Save As" menu command to save the uploaded flight program as a ".msc" file.

RECCOMENDATION: After putting your flight program to CONTROL, do a "Control Get Control" to get the flight program and verify it.

3.2 Basic Hardware Features

External connections to CONTROL are made through the eight pin header at one end of the board (see Appendix B).

External Battery Connections

Although it is possible to mount 9V battery clips onto CONTROL (Section 4.2), an external battery connection is recommended to minimize the possibility of loss of power during high-G events. A 9V alkaline battery is satisfactory for most flights. Larger rockets with multiple pyro events may prefer to use a R/C NiMH or NiCd battery pack, either 7.2 or 9.6 V. The minimum recommended battery voltage is +6.5 V. The absolute maximum allowable battery voltage is +15 V. The simplest external battery hookup uses the on-board power switch and is depicted in Figure 3.2a.

DANGER! Exceeding +15 V to CONTROL can irreversibly damage the electronics. OBSERVE POWER SUPPLY POLARITY REQUIREMENTS. Reversal of polarity, even momentarily, can irreversible damage the electronics

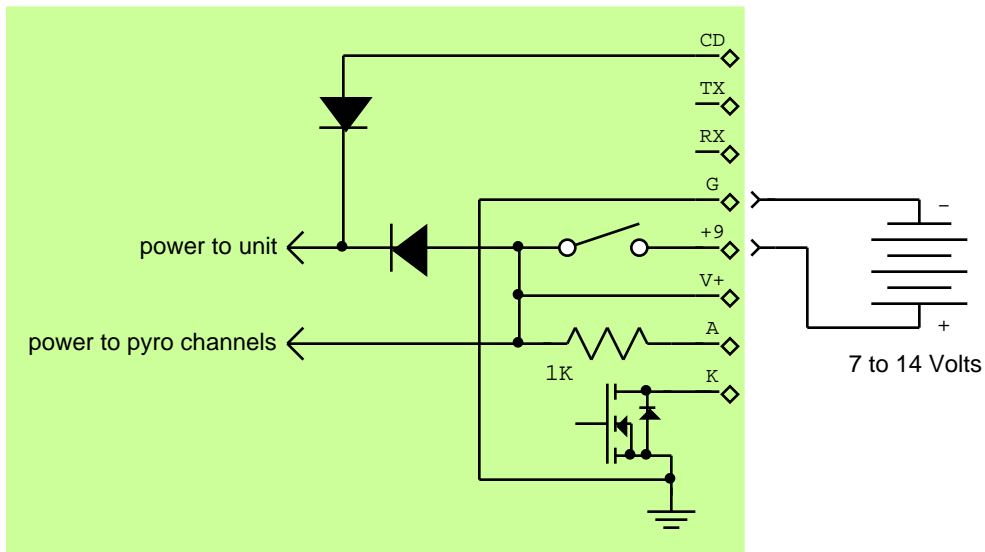

Figure 3.2a CONTROL External Battery Hookup

External Power Switch

The on-board power switch is not a heavy-duty design and is recommended only for minimum-ID installations where the bulk of an external switch is prohibitive. Adding an external power switch to the external battery hookup is shown schematically in Figure 3.2b.

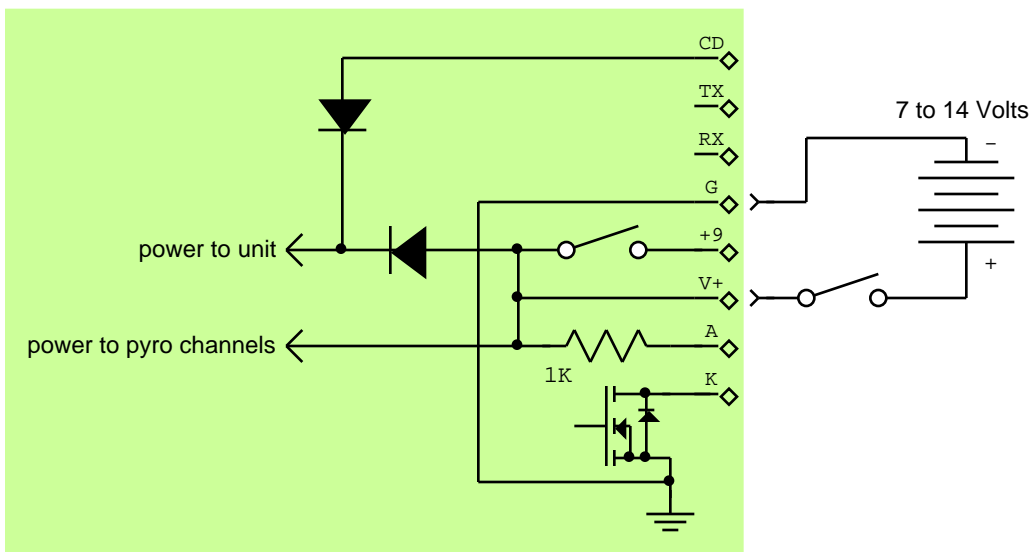

Figure 3.2b CONTROL with External Battery and Switch

CAUTION: Observe the LED anode/cathode polarity requirement to avoid damage to the LED (although CONTROL will remain unharmed in the event of a reverse connection).

External Beeper

An external piezo beeper may be added to CONTROL. The beeper must be of the self-oscillating type and should be low current. The beeper must also be compatible with the selected CONTROL power supply voltage. An example of a suitable device is Radio Shack 237-074A, which operates over a voltage range of 3 to 16 V and draws 12 mA at 12 V. Figure 3.2d depicts the schematic for a piezo beeper connection. Compare this schematic with the schematic of Figure 3.2b and observe that one side of the piezo beeper is connected to the positive battery terminal.

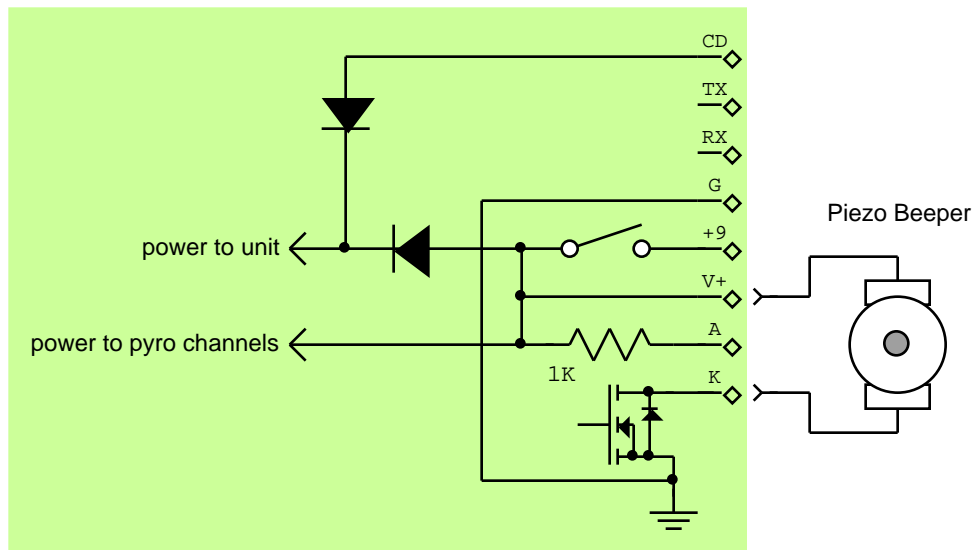

Figure 3.2d Control Piezo Beeper Connection

CAUTION: Observe the piezo beeper polarity requirement to avoid damage to the beeper. A reverse connection could also destroy the drive transistor at the 'K' pin of CONTROL. DO NOT SHORT THE 'V+' PIN TO THE 'K' PIN. Doing so may destroy the output drive transistor.

3.3 Ground Testing

Ground testing is an essential part of any flight plan. Ground test CONTROL to ensure that the observed behavior is the expected behavior. Although a small pressure chamber is ideal for testing CONTROL (one can be constructed out of a short piece of clear tubing), simpler methods generally suffice.

Pressure Triggering

A launch event can be simulated by briefly sucking on the MPX4100A pressure sensor if the "Alt launch detect" event is enabled. To simulate a launch profile with pressure triggering:

- 1) Connect test lamps to the required pyro channels.
- 2) Power CONTROL 'on' and hold in a horizontal position until the rapid LED blinking indicating "armed" commences. Holding the unit horizontal establishes zero G's as the launch reference acceleration.
- 3) Rotate CONTROL into normal position with "This End Up" facing up and quickly suck on the pressure sensor to trigger a launch event. The vertical orientation now acts as a one G launch acceleration.
- 4) After a second or two, rotate CONTROL into an inverted position with "This End Up" facing down. This simulates a negative G acceleration and a burnout event. If an airstart event is enabled the AIR channel will fire.
- 5) If "Acc apogee detect" only is enabled, CONTROL will generate an apogee detect event after a "down" time approximately equal to the previous "up" time and then fire the PEAK channel.
- 6) Altitude trigger events will now occur in rapid sequence as the unit is not actually at altitude (decreased atmospheric pressure), for instance firing the FLOOR pyro channel, and the simulation will be complete after a few seconds.

Acceleration Triggering

Normally the "Acc launch detect" threshold is set greater than two G's and it is very difficult to get CONTROL to detect launch by a simulated acceleration event, although this can be achieved by rapidly swinging the unit in an arc with "This End Up" pointing out. The easy way to simulate an acceleration launch event is to first modify the flight program to use an "Acceleration threshold" of about 1.5 G.

With "Acc launch detect" enabled and the "Acceleration threshold" set to 1.5 G:

- 1) Connect test lamps to the required pyro channels.
- 2) Power CONTROL 'on' and hold in a 45° "down" position until the rapid LED blinking indicating "armed" commences. Holding the unit slightly down establishes a negative G level as the launch reference acceleration.
- 3) Rotate CONTROL into normal position with "This End Up" facing up and quickly to trigger a launch event. The vertical orientation now acts as a launch acceleration.
- 4) After a second or two, rotate CONTROL into a fully inverted position with "This End Up" facing directly down. Pointing down at a greater angle than the pre-launch angle simulates a negative G acceleration and a burnout event. If an airstart event is enabled the AIR channel will fire.
- 5) If "Acc apogee detect" only is enabled, CONTROL will generate an apogee detect event after a "down" time greater than the previous "up" time and then fire the PEAK channel.
- 6) Altitude trigger events will now occur in rapid sequence as the unit is not actually at altitude (decreased atmospheric pressure), for instance firing the FLOOR pyro channel, and the simulation will be complete after a few seconds.

CAUTION: Do NOT leave the acceleration threshold parameter at a value less than 2.1 G without a very good reason. Rapid rotation of CONTROL with an acceleration threshold less than 2.1 G can trigger a launch event and lead to premature firing of the pyro channels!

4. Advanced Flights

Although the PC application *N-CONTROL* supports a great variety of flight configurations with just a few clicks of the mouse and a few strikes of the keyboard, that is not always good enough for a complex HPR flight. That is why *N-CONTROL* also supports the capability in *CONTROL* of *fully programmable state configuration*. Multiple airstarts, drop-away strap-on boosters, parachute shroud release on landing -- if you can think of it, a custom *CONTROL* flight program can help you achieve it.

4.1 Advanced Flight Programming

The State Machine

In Section 3 we discussed how *CONTROL* moves between various flight states from launch through landing. Each of the basic flight configurations is actually a specific "program" for a more general *state machine design*. Every *CONTROL* flight starts in a pre-launch "self-test" state, moves through one to eight configurable "flight" states, and finishes in the "idle" state. This is depicted in Figure 4.1a.

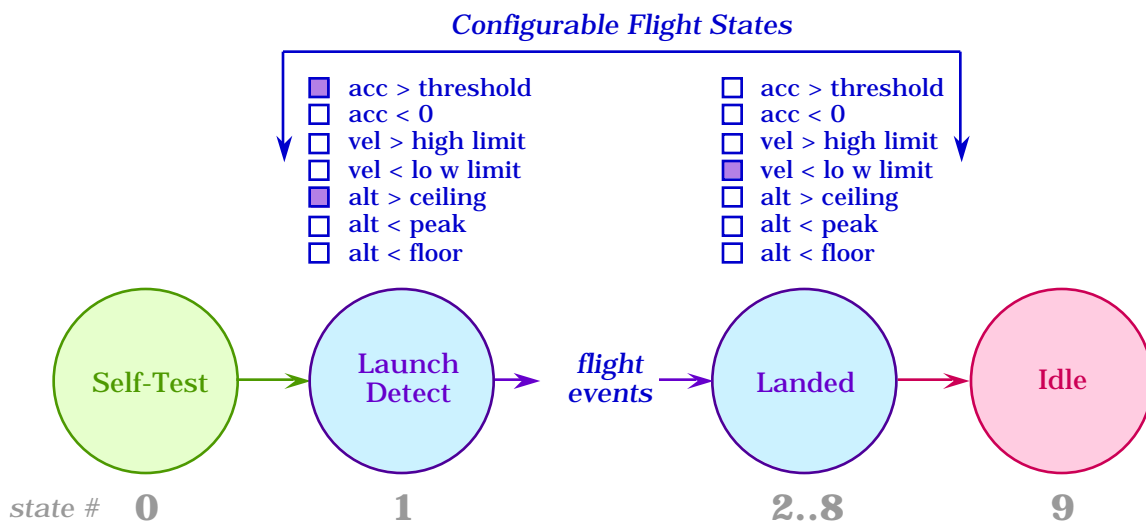

Figure 4.1a. *CONTROL* State Sequencing

The first configurable state is the "launch detect" state. Subsequent states usually correspond to specific flight phases such as "burnout detect", "ascend to apogee", or "descend to main deploy altitude". Movement from state to state is triggered by selectable *flight events*. Movement out of the launch detect state starts a *flight timer* running. Subsequent state transitions are marked by capturing the current flight time into a *flight event timer*. During the flight, the output pyro

channels are fired at programmable delays from selected flight event timers. After all flight states are completed, CONTROL sleeps in the idle state until turned off.

Flight Events

Detectable flight events and their minimum duration to be recognized are summarized in Table IV below.

Event	Typical Usage	Ticks
acceleration > threshold	launch detect, airstart detect	3
acceleration < 0	motor burnout	3
velocity > high limit	falling without parachute	49
velocity < low limit	landed	97
velocity < zero	apogee detect	2
altitude > ceiling	barometric launch detect	3
altitude < peak	drogue deploy	6
altitude < floor	mains deploy	8
auxiliary channel closed	fire backup charge if switch closed	3
auxiliary channel open	pull-pin launch detect	3

Table IV. State Transition Flight Events

The “ticks” column in the table above indicates the number of consecutive samples (at 16 Hz) that the event must be valid for before it actually triggers a state transition.

Programming the States

A state is programmed by (1) selecting the flight events that will end the state and move to the following state, (2) programming an optional state timeout that will also end the state and start the following state, and (3) selecting a LED blink pattern that distinguishes the state. To program a state using *N-CONTROL*, open a flight window and select either the **Control** or **Parameters** tab. Next, select the States... item from the **Control** menu to edit the states programming. *Hint:* try first selecting the basic flight configuration that most closely matches your planned flight, then proceed to edit that configuration.

Step through the states starting with state 0 (launch detect) until all required states are defined. Unused states should be set “idle” with no state events enabled.

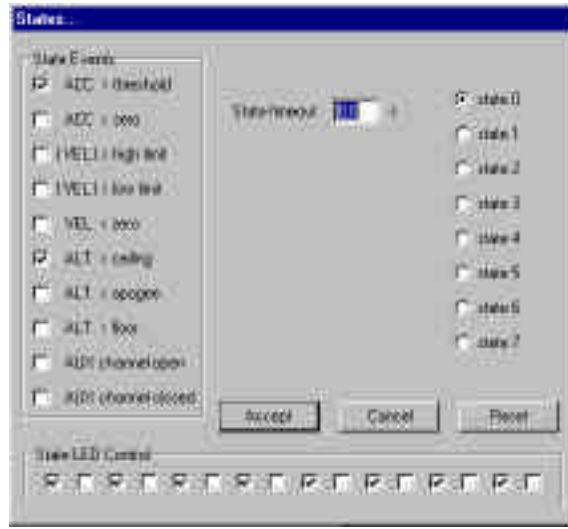

4.1b States... Configuration Dialog

State index	Select the state index (1..8) that you want to view or modify. States increment in sequential order during a flight.
State timeout	Select a state timeout interval. A timeout of zero corresponds to no timeout (infinity). The valid domain for a state timeout entry is 0 to 4095.9 seconds.
State Events	Check the desired state events. Parameters corresponding to these events are set on the Parameters tab. Note that it is usually meaningless to select certain combinations of events (such as ALT < apogee <i>and</i> ALT < floor).
State LED Control	Checked boxes correspond to the status LED being 'ON'. Each box represents 1/16 of a second for a repeating cycle. This allows you to set your own LED flashing sequences.
Accept	Accept the edited states program.
Cancel	Reject any edits made in the current dialog. The previous states program is retained.

CAUTION: A state with no programmed events and no state timeout is an IDLE state. CONTROL will never exit an idle state until powered off and on again, or by resetting using Open Host Protocols described in Appendix E. Unused states should be programmed to be idle states. If all eight states are programmed with events or timeouts, CONTROL will automatically go to a last idle state.

CAUTION: You should NOT program a state timeout for the launch detect state (generally state #1). If you have to ask why, you should not be trying to program CONTROL using the methods in this section!

RECCOMENDATION: A ".pdf" worksheet is available to pre-plan flight states. Use this sheet to minimize the possibility of error, and to better document your complex flights. Review the programmed states against the worksheet.

DANGER! There is nothing to prevent you from specifying an invalid sequence of events or states! ALWAYS GROUND TEST A CUSTOM FLIGHT CONFIGURATION. FAILURE TO GROUND TEST A CUSTOM FLIGHT CONFIGURATION CAN RESULT IN LOSS OF YOUR ROCKET!

Programming the Pyro Channels

Programming a pyro channel consists of (1) selecting a reference flight event timer, and (2) programming the time delay from that flight event until the pyro channel is fired. Each channel may also be programmed to either pulse 'ON' for one half second, or to latch 'ON' for the duration of the flight.



4.1c Channels... Configuration Dialog

Fire airstart Check to enable firing of the airstart channel; specify delay and trigger event state (event occurs at state exit); check "latch" to keep trigger 'ON' for the duration of the flight.

The airstart channel is typically used for either motor airstarts or for sustainer ignition.

Fire peak Check to enable firing of the peak channel; specify delay and trigger event state (event occurs at state exit); check "latch" to keep trigger 'ON' for the duration of the flight.

The peak channel is typically used for apogee deployment of a main parachute for a single deploy flight, or for a drogue parachute in a dual deploy flight.

Fire floor Check to enable firing of the airstart channel; specify delay and trigger event state (event occurs at state exit); check "latch" to keep trigger 'ON' for the duration of the flight.

The floor channel is typically used for low altitude deployment of a main parachute for a dual deploy flight.

Fire auxiliary Check to enable firing of the airstart channel; specify delay and trigger event state (event occurs at state exit); check "latch" to keep trigger 'ON' for the duration of the flight.

The auxiliary channel is available for miscellaneous pyrotechnic events such as:

- second airstart;
- booster separation;
- nosecone blow before drogue deploy;
- triggering a smoke charge;
- shroud release after landing to prevent drag damage.

Although the four pyrotechnic trigger channels have “typical” uses, remember that they are functionally equivalent, except that the auxiliary channel can also be used as a switch sense input (Section 4.2).

Pre-Flight Self-Tests

To complete programming of a customized CONTROL flight configuration, enable pertinent self-tests. CONTROL will not arm if any of the selected self-tests fail.

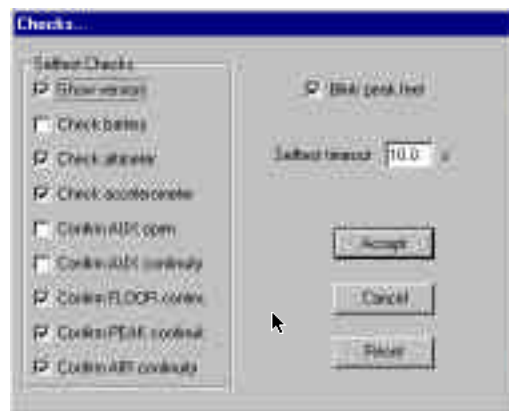

4.1d Checks... Configuration Dialog

Show version	Check to dump firmware version information over the CONTROL serial port when starting the pre-flight self-tests.
Check battery	Check to test that the battery voltage is greater than the minimum battery voltage parameter.
Check altimeter	Check the altimeter output to confirm basic operation of the barometric pressure sensor.

Check accelerometer	Check to accelerometer output to confirm basic operation.
Confirm AUX open	Check to require <u>no</u> continuity (switch open) between the auxiliary trigger channel terminals at the time of the prelaunch tests.
Confirm AUX continuity	Check to <u>require</u> continuity (switch closed) between the auxiliary trigger channel terminals at the time of the prelaunch tests.
Confirm FLOOR continuity	Check to <u>require</u> continuity between the floor trigger channel terminals at the time of the prelaunch tests.
Confirm PEAK continuity	Check to <u>require</u> continuity between the peak trigger channel terminals at the time of the prelaunch tests.
Confirm AIR continuity	Check to <u>require</u> continuity between the airstart trigger channel terminals at the time of the prelaunch tests.
Blink peak feet	Check to blink the post-flight peak altitude when in the idle state . <i>not implemented</i>
Selftest timeout	Set the post-test delay to allow the major component of acceleration and altimeter sensor power-on drift to pass. A minimum value of ten seconds is recommended.

NOTE: A pre-flight test of trigger channel continuity is not required to be able to fire that channel.

RECOMMENDATION: When wiring cluster ignitors, wire the ignitors in series. In addition to more reliably achieving simultaneous ignition, this allows CONTROL to not arm if there is a continuity problem with one of the ignitors. If they were wired in parallel, then both would have to be bad for CONTROL to not arm (when the appropriate continuity test has been enabled).

4.2 Advanced Hardware Features

In addition to allowing more complex flight profiles, advance flight programs also can make use of some additional hardware features.

Auxiliary Channel as a Switch Input

The auxiliary channel may be programmed to sense a switch either opening or closing as an event.

LED Output as an Additional Channel

The LED drive pin "K" may be used as a general purpose switch to control external loads. When "ON", the output transistor sinks current to ground (250 mA maximum). This may be used for miscellaneous control functions such as driving an RF locator transmitter or flashing a large external strobe for night flights by programming the LED flashing sequence.

On-Board Battery Clips

In some instances it is inconvenient to use an external battery cable. Battery clips for a standard 9V battery may be installed on the same side of the PC board as the screw terminals for the pyro trigger channels.

CAUTION: DO NOT attempt to install on-board battery clips unless you know what you are doing. DO NOT INSTALL BATTERY CLIPS WITH AN INCORRECT POLARITY. DAMAGE TO THE BOARD FROM USER MODIFICATIONS IS NOT WARRANTEED. If you would like to have on-board battery clips installed you can return you board to *DefyGravity* to have this work performed for a nominal fee.

DANGER: When using the on-board battery clips, the battery can become disconnected by inertial forces during severe deceleration. THIS CAN RESULT IN A RECOVERY SYSTEM FAILURE. As an extra measure you can wrap a couple of layers of masking tape around the battery and board. An external battery connection with secure connections is the best way to avoid this potential failure mode.

Separate Pyro Power Supply

It is possible to use a separate pyro supply to avoid the possibility of a large current draw creating a voltage "brownout" condition that could affect the normal operation of CONTROL.

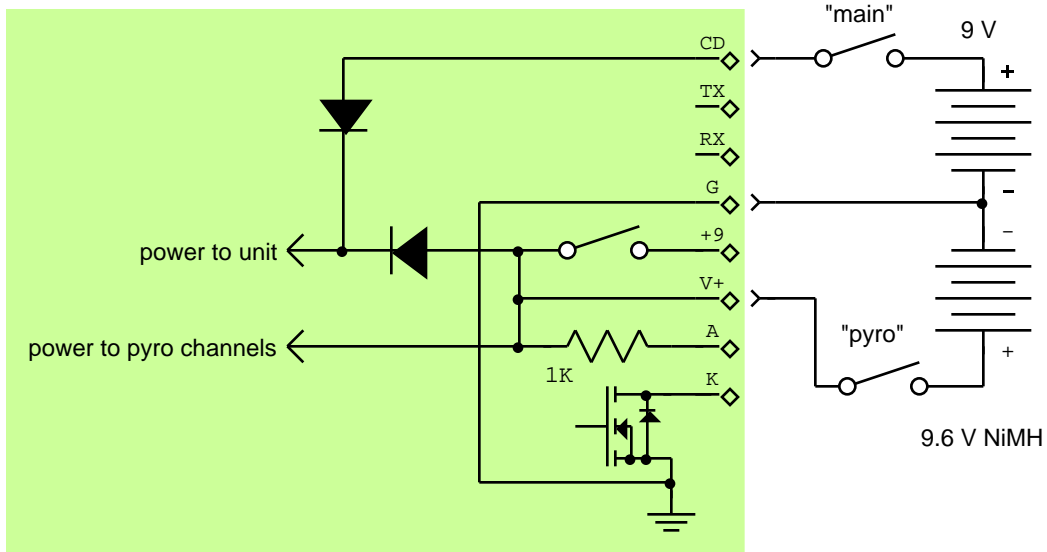

4.2a Separate CONTROL Power Supplies

Note the use of separate external power switches.

NOTE: Power must be applied to the pyro channels before the "trigger continuity" self tests will pass. Either the self tests can be disabled, or, if necessary, power to the pyro channels can be removed after the self tests are passed. **POWER MUST BE APPLIED TO THE PYRO CHANNELS FOR THE PYRO TRIGGER CHANNELS TO ACTUALLY FIRE!**

In-Flight Coprocessor Communications

CONTROL continually transmits altitude and pressure digital numbers (DN) out the serial port after passing the pre-launch self-tests and during flight. This data may be passed to either an external data transmission unit or another processor for additional data processing.

An external processor may also control CONTROL using the Open Host Interfaces documented in Appendix E. Do not, however, configure flight programming and parameters during a flight.

4.3 Unit Calibration

Each CONTROL unit is individually calibrated when the initial firmware program is loaded into FLASH memory. Unit calibration should be checked on a yearly basis, or after a major flight “event” such as a hard landing from a recovery system failure.

Calibration of a CONTROL unit sets the digital number to MKS unit conversions for the accelerometer and pressure sensors. The calibration parameters are stored in the unit’s EEPROM memory. Note that most of the display values in *N-CONTROL* are relative to launch conditions, and unit calibration has little effect on these values.



4.3a Control Calibrate... Dialog

Version	Control internal firmware version number.
Serial #	Unique device identifier.
Battery	Present battery supply voltage.
ACC slope	DN to acceleration conversion constant; should be near 1.0.
ACC offset	Acceleration DN offset; optimal value is zero.
ALT slope	DN to barometric pressure altitude conversion constant; should be near 1.0.
ALT offset	Pressure altitude DN offset; optimal value is zero.
Altitude	Present ground altitude.
Pressure	Present ground barometric pressure.

Altitude Calibration

- 1) Connect CONTROL to your PC and open the *N-CONTROL* application,
- 2) Chose "Control ... Calibrate..." to activate the dialog displayed in Figure 4.3a.
- 3) Enter your present elevation MSL into the "Altitude" edit box.
- 4) Enter your present barometric pressure into the "Pressure" edit box.

Barometric pressure should be obtained from a temperature compensated barometer located at your site. If an independent barometric pressure is not available, do not edit the displayed value.

Accelerometer Calibration

- 1) Connect CONTROL to your PC and open the *N-CONTROL* application,
- 2) Chose "Control ... Calibrate..." to activate the dialog displayed in Figure 4.3a.
- 3) Press the button "Calibrate ACC" to display the dialog of Figure 4.3b.
- 4) Hold the "This end up" end of Control "up" and slowly rotate the unit around this direction to obtain the highest "Max" acceleration reading.
- 5) Slowly rotate Control until "This end up" is pointing "down" and slowly rotate the unit around this directon to obtain the lowest (most negative) "Min" acceleration reading.
- 6) Press "Accept" to accept the new calibration and to return to the previous dialog; press "Cancel" to retain the present acceleration calibration values.



4.3b Interactive Calibrate Accelerometer Dialog

Repeating steps 3 .. 5 should show a maximum reading of +1.00 G and a minimum reading of -1.00 G.

4.4 Firmware Updates

5. Rocket Science

This section is dedicated to showing some of the “how” of CONTROL’s operation.

5.1 Understanding the Accelerometer

The acceleration sensor is an Analog Devices ADXL150 micromachined integrated circuit. The actual acceleration sensor is a cantilevered arm with a small proof mass at one end and an integrated capacitive sensor. On-chip electronics generates a temperature compensated output voltage proportional to the acceleration sensed along one preferred axis with a nominal range of ± 50 G.

The accelerometer circuit senses a +1 G acceleration when CONTROL is oriented vertically with “This End Up” and held still. This +1 G acceleration is due to Earth’s gravitational field.

5.2 Understanding the Altimeter

The altitude sensor is a Motorola MXP4100A pressure sensor.

Pressure to altitude conversion is implemented in the *N-CONTROL* application using the US 1976 Standard Atmosphere Model.

5.3 Understanding Data Sampling

CONTROL acquires acceleration and pressure data at a 16 Hz rate with 12 bits of precision (1 part in 4096). The unprocessed acceleration and pressure data samples are continually written into EEPROM from the prelaunch state until approximately 500 seconds after launch detect. Data logging stops at that time to prevent overwriting of earlier flight data, but all other operations continue normally.

NOTE: Precision is not accuracy! Although acceleration and pressure are measured to about .025%, sensor and data converter noise and drift limit the absolute accuracy to about 2%. Other flight factors, such as rocket angle-of-attack and atmospheric temperature profile can degrade the accuracy of acceleration and pressure measurements even further.

A. Specifications

CONTROL Avionics

English units in (..)

Parameter	Value	Note
Acceleration, measuring range	-50 .. +50 G	sensor limits
Acceleration, accuracy	± 2 %	sensor limit
Acceleration, damage threshold	200 G	0.5 ms limit ¹
Altimeter, measuring range	-0.3 .. 11.8 km (-990 .. 38700 ft)	1050 .. 200 mbar ²
Altimeter, valid range	0 .. 11.0 km (0 .. 35000 ft)	1013 .. 240 mbar ³
Altimeter, accuracy	± 1.8 %	sensor limit ⁴
Communications Rate	57.6 KBaud	RS-232 ⁵
Connector, compatible housing		
Dimensions, envelope	xx (xx)	with 9V battery
Dimension, mounting	xx (xx)	dia. ⁶
Humidity, operating	5 .. 95 %	non-condensing
Humidity, non-operating	0 .. 95%	non-condensing ⁷
Sensors, measurement resolution	.025 %	12-bit ADC
Supply Voltage	5.7 .. 15.0 V	DC
Supply Current		prelaunch nom.
Temperature, operating	0 .. 70 C (32 .. 158 F)	component limit
Temperature, non-operating	-40 .. 125 C (-40 .. 257 F)	component limit
Weight		without battery

Notes:

- 1) Acceleration damage can occur at lower thresholds with improper mounting.
- 2) Sensor limit.
- 3) Per 1976 Standard Atmosphere Model.
- 4) Non-accelerating.
- 5) TX/RX rate, 8 bits per character, no parity, one stop bit
- 6) use #4 mounting hardware
- 7) Do not immerse. Store at low humidity for longest pressure sensor life.

N-C ONTROL Software System Requirements

Win32 OS API

486 or higher processor

16 Mbyte RAM or greater

800 x 600 minimum display, prefer 256 or greater colors

CDROM for software installation

.www access for software updates

RS-232, 57.6 KBaud serial port

C. Standard Configurations

1	Initial Configuration	The initial "out-of-the-box" flight program. Available as "standard.msc".
2	Deploy at Apogee	Deploy main parachute apogee. A basic flight configuration.
3	Dual Deploy	Deploy drogue parachute at apogee, followed by main parachute at descent "floor". A basic flight configuration.
4	Dual Deploy with Airstart	Do airstart at first burnout detect. Deploy drogue parachute at apogee, followed by main parachute at descent "floor". A basic flight configuration.
5	Logging Only	Acquire flight data only. A basic flight configuration

D. PC File Format

PARAMETER <setparam> <mks>

EVT <state> <event>

TMR <state> <secs>

LED <state> <bits>

CHECKS <check>

SELFTTEST <flag> <secs>

AIR_DELAY <tmr> <secs>

PEAK_DELAY <tmr> <secs>

FLOOR_DELAY <tmr> <secs>

AUX_DELAY <tmr> <secs>

FLIGHT <fltparam> <mks>

SITE <string>

FLYER <string>

SAMPLES <int>

<setparam> -> Flight#ID
 -> UnitID
 -> LaunchDelta
 -> AscentCeil
 -> ApogeeDelta
 -> DescentFloor
 -> LandingDelta
 -> DescentLimit
 -> MinBattery

<fltparam> -> FlightTime
 -> EventTime <N>
 -> Time@ <pyro>

- > Battery@ <pyro>
- > Battery@launch
- > RefAlt
- > RefAcc
- > LaunchTemperature
- > PeakAlt
- > Flight#ID

<event>

- > eLaunch
- > eCeiling
- > eBurnout
- > eApogee
- > ePeak
- > eFloor
- > eLanded

<check>

- > cBatt
- > cAlt
- > cPeak
- > sFeet
- > sVers

E. Open Host Interface

The serial communications *Open Host Interface* (OHI) for CONTROL configuration and data download allows development of custom applications. Using OHI, a custom application can:

- acquire acceleration and altimeter data during flight;
- download post-flight data;
- access the flight events table;
- read and modify flight parameters; and,
- read and modify the flight configuration.

The OHI allows not only development of display and configuration software for new hardware platforms, but also allows for in-flight integration of CONTROL into sophisticated flight systems.

RS-232 Port Configuration

An OHI application communicates with CONTROL using a RS-232 physical interface, as is depicted in Figure E1. Serial communications are fixed at 19200 Baud, eight data bits per character, no parity bit, and one stop bit.

Figure E1. OHI Communications

Most OHI transactions use printable alphanumeric characters to specify commands and standard decimal integers for data transfers. The interface can be accessed manually using a standard serial terminal emulation program.

DANGER! While the OHI protocols greatly expand the utility of CONTROL, and reading (download) of data through this interface is quite safe and controlled, PROTOCOL WRITES TO EEPROM CAN CAUSE UNSTABLE OPERATION THROUGH INCORRECT AND INVALID CONFIGURATIONS. ALWAYS THOROUGHLY GROUND TEST AND DEBUG A NEW APPLICATION BEFORE APPLYING IT TO ACTUAL FLIGHT CONFIGURATIONS. CONDUCT FIRST FLIGHT TESTS WITH THE UNIT AS "PAYLOAD ONLY". FAILURE TO HEED THIS ADVICE CAN RESULT IN LOSS OF YOUR ROCKET!

OHI Protocols

OHI protocols allow (1) read/write access to flight log and flight configuration EEPROM, and, (2) display of current sensor readings. The software model for the OHI “server” that is always executing on CONTROL (while power is on) is depicted in Figure E2.

Figure E2. OHI Server Software Model

OHI SERVER	receive character driven state machine
RX DATA	8-bit serial receive data register
TX DATA	8-bit serial transmit data register
ACCUMULATOR	16-bit user input data value
EE POINTER	15-bit word address register into EEPROM
ADC12	12-bit analog to digital converter
MUX8	8-channel analog multiplexer

EEPROM Layout

All data for flight configuration, events history, and flight data logging of accelerometer and altimeter readings is stored in OHI accessible EEPROM. The CONTROL EEPROM allows storage of 32768 “words” of data. This storage is logically divided into four partitions:

logging data	storage for pre-flight and in-flight accelerometer and pressure altimeter readings;
flight parameters	numeric flight configuration data such as launch detect acceleration, ceiling and floor altitudes, etc.;
flight events	record of flight event timers and other in-flight sampled data such as temperature and battery voltage at pyro trigger events; and,
states program	state transition events tables, state timeout parameters, and LED status sequences

These partitions and their addressing limits are depicted in Figure E3.

Figure E3. EEPROM Data Partitions

CAUTION: EEPROM words labeled "read-only" SHOULD NOT be written to, although there is nothing in the hardware to prevent that. Writing to one of these locations will generally cause CONTROL to re-initialize EEPROM from it's default (FLASH memory) configuration upon power-up.

Parameter	Address	Rd-Only	Description
EEkeyHi	16383		EEPROM valid high key ('MC')
EEkeyLo	16382		EEPROM valid low key ('v2')
Version	16381	yes	firmware version
SET_28	16380	-	reserved
SET_27	16379	-	reserved
SET_26	16378	-	reserved
SET_25	16377	-	reserved
BatteryLo	16376		low battery voltage threshold
SET_23	16375	-	reserved
SET_22	16374	-	reserved
SET_21	16373	-	reserved
SET_20	16372	-	reserved
AuxTimeout	16371		auxiliary channel timeout & source
FloorTimeout	16370		floor channel timeout & source
PeakTimeout	16369		peak channel timeout & source
AirTimeout	16368		airstart channel timeout & source
VelHiLimit	16367		"falling" velocity limit
VelLoLimit	16366		"landed" velocity limit
FloorAlt	16365		floor altitude
PeakDelta	16364		pressure apogee detect threshold
CeilingAlt	16363		ceiling altitude
LaunchAcc	16362		launch acceleration threshold
			(IEEE float32)
AltSlope	16360		pressure altitude offset slope
	16359		(IEEE float32)
AltOffset	16358		pressure altitude offset calibration
			(IEEE float32)
AccSlope	16356		accelerometer slope calibration
			(IEEE float32)
AccOffset	16354		accelerometer offset calibration
UnitSerial	16353	yes	unit serial number
FlightNum	16352	yes	sequential flight number

Parameter	Address	Rd-Only	Description
FlightNum2	16351	yes	sequential flight number
FLT_30	16350	-	<i>reserved</i>
FLT_29	16349	-	<i>reserved</i>
FLT_28	16348	-	<i>reserved</i>
FLT_27	16347	-	<i>reserved</i>
FLT_26	16346	-	<i>reserved</i>
FLT_25	16345	-	<i>reserved</i>
FLT_24	16344	-	<i>reserved</i>
FLT_23	16343	-	<i>reserved</i>
PeakAlt	16342	yes	peak pressure altitude
EEendOffset	16341	yes	last used EEPROM word offset
EEbegOffset	16340	yes	EEPROM word offset at launch
LaunchBatt	16339	yes	battery voltage at launch
LaunchTemp	16338	yes	temperature at launch
RefAcc	16337	yes	launch reference acceleration
RefAlt	16336	yes	launch reference pressure altitude
FLT_15	16335	yes	<i>reserved</i>
FLT_14	16334	yes	<i>reserved</i>
VdsAux	16333	yes	auxiliary channel voltage at firing
VdsFloor	16332	yes	floor channel voltage at firing
VdsPeak	16331	yes	peak channel voltage at firing
VdsAir	16330	yes	airstart channel voltage at firing
FLT_9	16329	-	<i>reserved</i>
FLT_8	16328	-	<i>reserved</i>
Timer7	16327	yes	state 7 -> idle tick capture
Timer6	16326	yes	state 6 -> 7 tick capture
Timer5	16325	yes	state 5 -> 6 tick capture
Timer4	16324	yes	state 4 -> 5 tick capture
Timer3	16323	yes	state 3 -> 4 tick capture
Timer2	16322	yes	state 2 -> 3 tick capture
Timer1	16321	yes	state 1 -> 2 tick capture
FlightTicks	16320	yes	flight ticks (16 Hz) since launch

Parameter	Address	Rd-Only	Description
SelftestTicks	16319		Selftest completion delay
SelftestFlags	16318		Selftest check flags
STATE_29	16317	-	<i>reserved</i>
LEDbits8	16316	yes	ALWAYS ZERO
LEDbits7	16315		state 7 LED flashing
LEDbits6	16314		state 6 LED flashing
LEDbits5	16313		state 5 LED flashing
LEDbits4	16312		state 4 LED flashing
LEDbits3	16311		state 3 LED flashing
LEDbits2	16310		state 2 LED flashing
LEDbits1	16309		state 1 LED flashing
LEDbits0	16308		launch detect LED flashing
STATE_19	16307	-	<i>reserved</i>
IDLETimeout	16306	yes	ALWAYS ZERO
StateTimeout7	16305		state 7 timeout ticks
StateTimeout6	16304		state 6 timeout ticks
StateTimeout5	16303		state 5 timeout ticks
StateTimeout4	16302		state 4 timeout ticks
StateTimeout3	16301		state 3 timeout ticks
StateTimeout2	16300		state 2 timeout ticks
StateTimeout1	16299		state 1 timeout ticks
LaunchTimeout	16298	yes	ALWAYS ZERO
STATE_9	16297	-	<i>reserved</i>
IdleFlags	16296	yes	ALWAYS ZERO
EvtFlags7	16295		state 7 event flags
EvtFlags6	16294		state 6 event flags
EvtFlags5	16293		state 5 event flags
EvtFlags4	16292		state 4 event flags
EvtFlags3	16291		state 3 event flags
EvtFlags2	16290		state 2 event flags
EvtFlags1	16289		state 1 event flags
LaunchFlags	16288		launch detect event flags

OHI Receive Finite State Machine

char	hex	action
------	-----	--------

!	21	start launch sequence
#	23	read back accumulator
0. . 9	30. . 39	add digit to accumulator
:	3A	read back address
;	3B	write accumulator to EEPROM
=	3D	zero accumulator
?	3F	read EEPROM word
@	40	copy accumulator to EEPROM address pointer
A	41	dump battery DN (12-bit)
B	42	dump acceleration DN (12-bit)
C	43	dump pressure DN (12-bit)
D	44	dump temperature DN (12-bit)
E	45	dump AUX channel Vds DN (12-bit)
F	46	dump AIR channel Vds DN (12-bit)
G	47	dump PEAK channel Vds DN (12-bit)
H	48	dunp FLOOR Vds DN (12-bit)
J	4A	dump average acceleration DN (16-bit)
K	4B	dump average pressure DN (16-bit)

F. Problem Report Form

G. Glossary

AGL <i>Above Ground Level</i>	altitude as measured from the launch point on the ground representing zero altitude.
DN <i>digital number</i>	uncorrected sensor reading.
MKS <i>meter-kilogram-second</i>	international system of metric units.
MSL <i>Mean Sea Level</i>	altitude as measured from mean sea level representing zero altitude. Equivalent to the topographic altitude.
“ceiling”	used within this document to represent an event or trigger associated with the act of being or ascending above the “ceiling” reference altitude.
“floor”	used within this document to represent an event or trigger associated with the act of being or descending below the “floor” reference altitude.
“peak”	used within this document to represent an event or trigger associated with the apogee altitude.

1. PC Host Communications Mode

Word16 accumulator, address, read_data

Byte character

Bool PCcommMode = TRUE

WHILE PCcommMode

 Wait for receive (character)

 character &= 0x7F

 ON(character)

 UPON('=')

 accumulator = 0

 UPON('@')

 address = accumulator

 UPON('?')

 read_data = *address

 address += 1

 Transmit (read_data) as decimal

 UPON(';')

 *address = accumulator

 address += 1

 UPON(':')

 Transmit (address) as decimal

 UPON('#')

 Transmit (accumulator) as decimal

 UPON('!')

 PCcommMode = FALSE

 `go to "debug" launch mode

 UPON('%')

 read_byte = *accumulator

 accumulator += 1

 Transmit (read_byte) as decimal `debug "peek"

 UPON(*) Transmit (adc_acceleration) as decimal

 UPON(+) Transmit (adc_pressure) as decimal

 UPON(,) Transmit (adc_floor) as decimal

 UPON(-) Transmit (adc_peak) as decimal

 UPON(.) Transmit (adc_auxiliary) as decimal

 UPON(/) Transmit (adc_airstart) as decimal

OTHEWISE

 IF(isDecimalDigit(character))

 accumulator *= 10

 accumulator += (character - '0')

ENDIF
ENDON
ENDWHILE

2. EEPROM Allocations

Word addresses 0 - 16319 reserved for data logging as (altitude, acceleration) word pairs.
Logged data is raw (not scaled or offset to "user" units).
Word addresses 16320-16383 reserved for setup, calibration, and flight parameters.
Parameter blocks are aligned within EEPROM pages (64 bytes/page).

All EEPROM values are treated as unsigned words (16-bit). Conversion to "user" parameters is via linear transformation,

$$\text{val} = (\text{dn} * \text{slope}) + \text{offset}$$

where,

val is float value in user units
dn is raw digital number (unsigned word)
slope is conversion slope in user units
offset is conversion offset in user units

Use of readback operators (':' '#' '?') is strongly recommended during programming to validate parameter values.